

XP308i

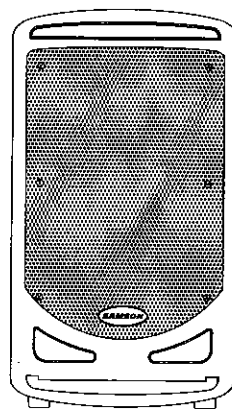
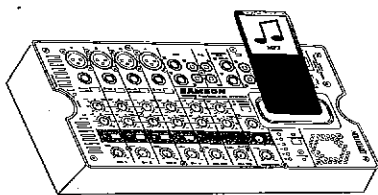
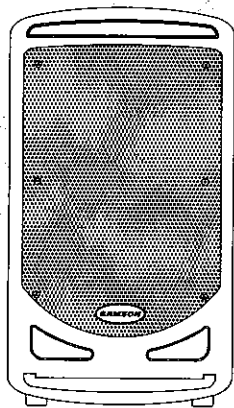

**300 PORTABLE PA SYSTEM
WITH iPod DOCK**

Owners Manual

SAMSON®

Portable PA System

XP308i Features

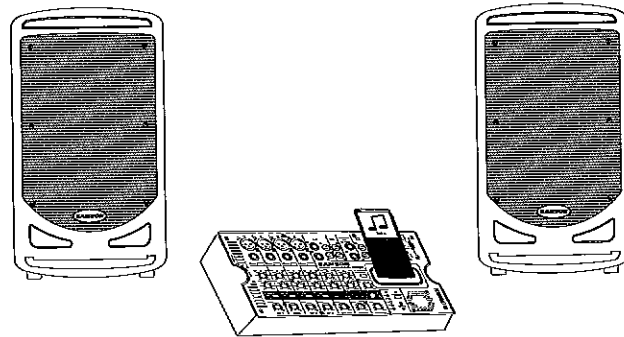

The Expedition XP308i PA system is an ideal solution for a variety of live sound applications. Here are some of its main features:

- The XP308i is a compact PA system with dual 2-way speakers, onboard mixer and 300 watt power amplifier.
- The XP308i is the ultimate in portable design. The lightweight and the clever design allow you to connect all the pieces together into a single easy to move case.
- The internal 2 x 150 watt lightweight Class D power amplifier produces a clean, loud, stereo sound.
- The speakers are 2-way vented enclosures with a heavy duty 8-inch woofers for deep bass complimented by a 1-inch titanium tweeter set in a custom horn with a 60 x 90 degree coverage pattern producing a clean and clear sound.
- The XP308i's 8-channel mixer can be removed from the speaker for tabletop use and you can use the kick stand to set the mixer on an ergonomically correct angle.
- The mixer features four Mic/Line inputs allowing you to connect microphones or line signals, plus two stereo inputs for connecting line signals from keyboards, drum machine and MP3/CD players. You can engage the Phantom Power switch if you are using condenser microphones.
- On each of the mixer's channel inputs there is a Bass and Treble control allowing you to contour the tone of the individual inputs.
- To create a lush vocal effect, you can use the internal effects processor to add Digital Reverb to any of the microphones channels.
- The XP308i features a built-in iPod dock allowing you to easily connect most iPod models for seamless music playback. You can use the ipod to simply play music, add background tracks, or repeat a commercial message at a fair or trade show.
- An overall system equalization contour can be set using the Music/Speech switch. Setting the switch to Speech adds a tone contour that will help articulate the voice and when the switch is set to Music a tone contour with slightly enhanced lows and highs is engaged.
- The six-segment Level Meter with LIMITER indicator helps you set a good clean level with minimal distortion.
- You can record your performance by connecting the RCA Record Outputs to an external recorder.
- For added flexibility, the XP308i's mixer has a Monitor Out on two, ¼ inch jacks allowing you to connect to external powered monitor speakers.

XP308i Speaker Layout

XP308i Front View Layout

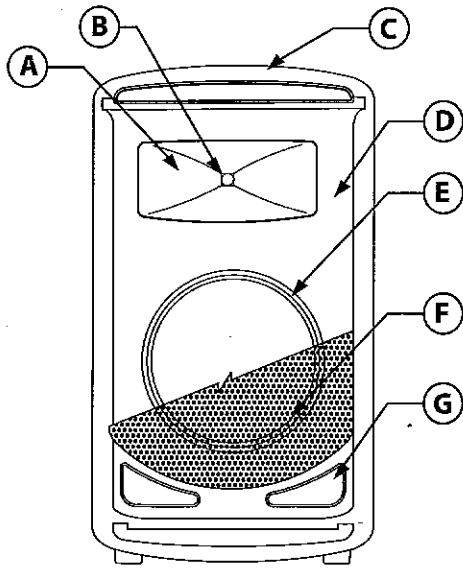

- A. Wide Dispersion Horn** – 1 inch throat, 60 x 90 degree wide dispersion horn provides extensive coverage and linear off-axis response.
- B. Titanium Tweeter Driver** – 1.35 inch (34mm), titanium diaphragm with 1 inch opening.
- C. Handle** – One of two ultra over sized rubber grip carry handles.
- D. Enclosure** – Thick-wall, rugged PVC plastic enclosure.
- E. 8-inch Driver** – Custom designed, high sensitivity, heavy-duty, 8" low frequency driver provides deep bass.
- F. Steel Grill** – Durable steel grill provides protection for, and easy access to LF driver.
- G. Bass Port** – Two precision tuned, low frequency port tubes extend the bass response.

XP308i Rear View Layout

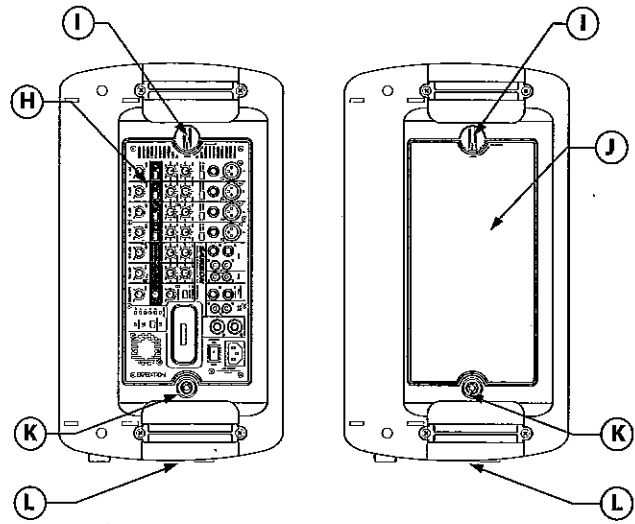

- H. Powered Mixer** – The XP308i's eight-channel, 300 watt powered mixer fits conveniently inside the one speaker enclosure.
- I. Quarter Turn Screw** – The mixer and accessory compartment panel are easily opened and closed using the built-in quarter turn screws.
- J. Accessory Compartment** – You can store your speaker cables or microphones inside one speaker enclosure by removing the accessory door using the quarter turn screws.
- K. INPUT - 1/4-inch phone jack** – Each speaker enclosure has an input on a 1/4-inch phone jack.
- L. Pole Mount** – The XP308i has integral 1 3/8 (35mm) speaker stand receptacle allowing the speakers to be set on standard speaker stands with no additional adapters required.

XP308i Quick Start

In the following pages of this manual, you will find a detailed explanation of all the XP308i's functions and controls, but if you just want to get started quickly you can follow the steps below.

Unpacking and Setting Up the XP308i

- Unpack all the system components from the shipping carton and save all the packing material in (the unlikely) case your unit ever needs to be returned for service.
- Remove the mixer by turning the quarter turn screw counter clockwise towards the RELEASE position.

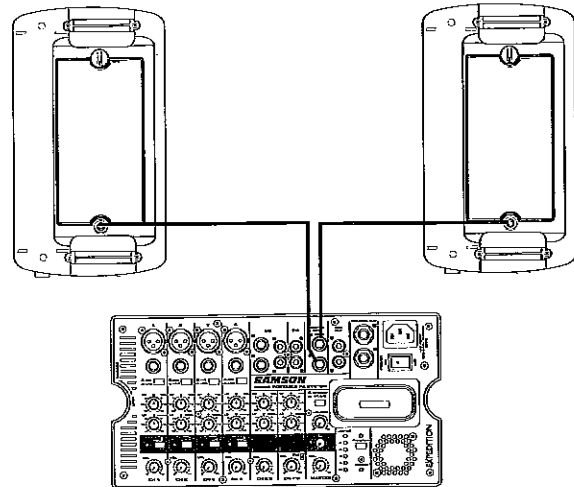
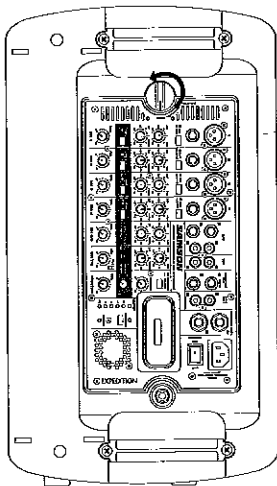

Using a Microphone

Be sure that the XP308i's Power switch is set to the off position.

- Turn all of the channel VOLUME (VOL) controls fully counterclockwise to the "0" position.
- If the speakers are not connected, connect the speaker's wire as described in the previous section.
- Next, connect the power cable to an AC socket.
- Using a standard XLR cable, plug a microphone into the XP308i's Channel 1 MIC INPUT.

IMPORTANT NOTE! – In order to ensure proper ventilation, always remove the mixer before powering it on.

- Remove the accessory compartment cover by turning the quarter turn screw counter clockwise towards the RELEASE position and remove the included speaker cables.
- Replace the accessory panel by aligning the bottom of the panel into the slots, make sure the quarter turn screw is in the RELEASE position, then close the panel and turn the quarter turn screw clockwise to LOCK.
- Position the speakers on the floor or on stands and using one of the included speaker cables, connect the mixer's LEFT SPEAKER OUT to the left speaker's input connector. Next use the second included speaker cable to connect the RIGHT SPEAKER OUT to the right speaker's input connector.

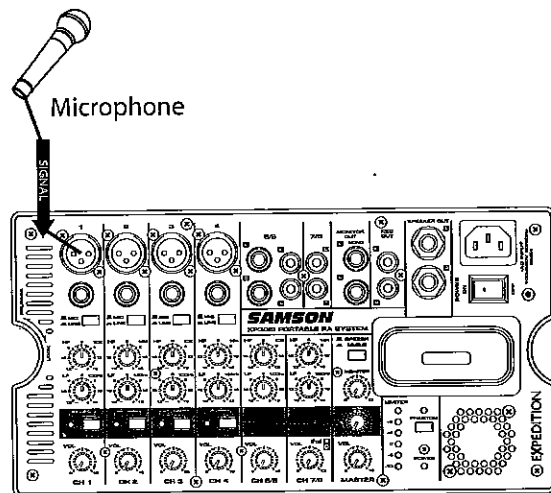

- Switch the XP308i's Power switch to the ON position.
- Set the Channel 1 VOLUME (VOL) control to about half way.
- While speaking into the microphone, slowly raise the MASTER level control until you have reached the desired level.

XP308i Quick Start

Using a Line Level Signal

- Be sure that the XP308i's Power switch is set to the OFF position.
- Turn the VOLUME controls fully counterclockwise to the off position.
- Connect the power cable to an AC socket.
- Using standard 1/4-inch cables, connect a line level signal from a keyboard into the XP308i's LINE INPUTS.

feedback. One possible exception is when you are adjusting the sounds of the microphones, since you want to listen in front of the speaker to hear properly. To do this, lower your mixers MASTER VOLUME while setting the EQ and effect from in front of the speakers. Once you have the sound you like, move the microphones to behind the speakers and raise the MASTER volume.

Speaker Placement

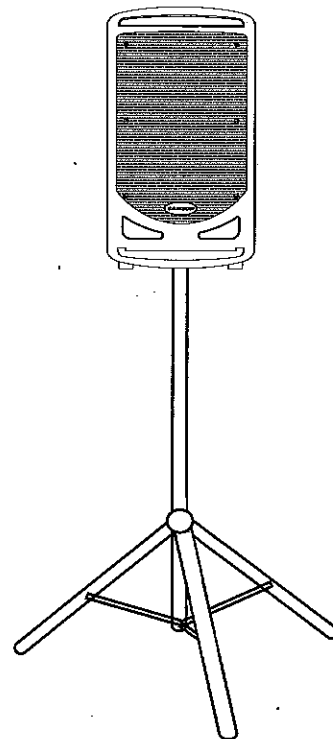
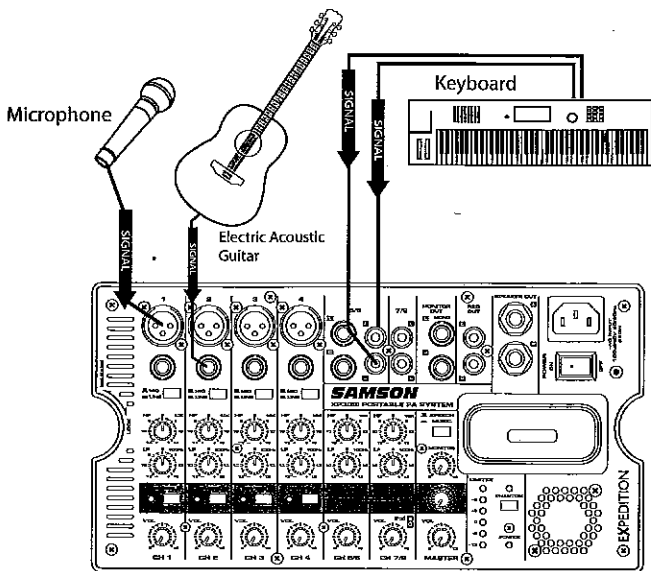

- Switch the XP308i's Power switch to the ON position.
- Now, play your guitar or keyboard and slowly raise the channel control and the MASTER level control until you have reached the desired VOLUME.

Microphone Positioning - How to Reduce Feedback

Feedback is the annoying howling and squealing that is heard when the microphone gets too close to the speaker and the volume is high. You get feedback when the microphone picks up the amplified signal from the speaker, and then amplifies through the speaker again, and then picks it up again, and so on and so on. In general, it is always recommended that any LIVE mic (a mic that's on) is positioned behind the speaker enclosures. This will give you the best level from your system before

Whenever possible, it is a good idea to raise the speakers above the heads of the listening audience. The XP308i enclosures feature standard 1 3/8" pole mount receptacles, which are compatible with speaker stands from a variety of manufacturers including the models LS2, TS50 and TS100 from Samson. In a smaller setting like a school cafeteria, library, or a mall kiosk, you can also use the XP308i on its side in the tilt back monitor position, which will improve the projection of the speakers and may eliminate the need for speaker stands.

XP308i Mixer Layout

XP308i Front View Layout

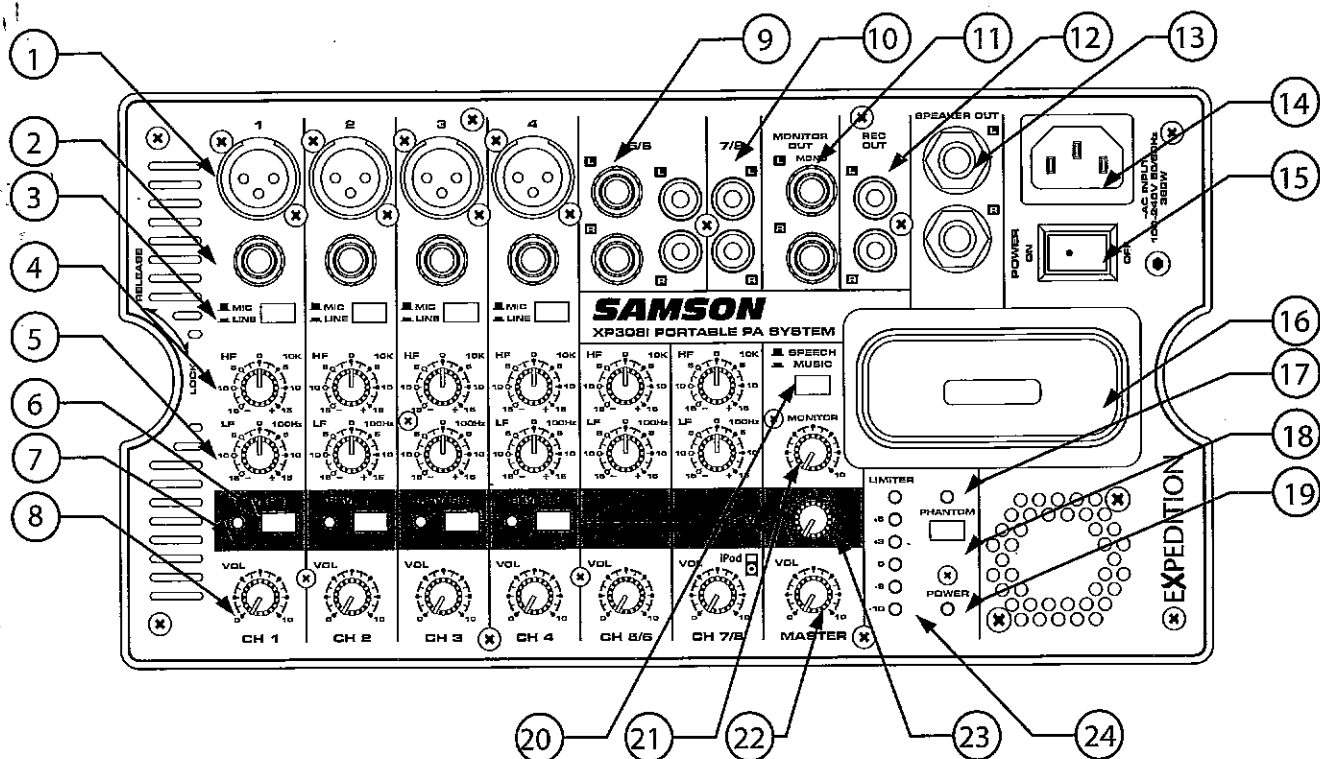

1. MIC – XLR connector (channels 1 - 4)

Use these XLR jacks to connect low impedance microphones to the XP308i's built-in mic preamps.

2. LINE - 1/4-inch phone connector (channels 1 - 4)

Use these 1/4" jacks to connect instrument or audio source with line-level signals to the XP308i. You can connect the outputs from acoustic guitar pickups, keyboards, drum machines, CD/MP3/TAPE players and other units with line level outputs here.

3. MIC/LINE – switch (channels 1 - 4)

The MIC position changes the gain of both input jacks to MiC level. The LINE position reduces the gain of both jacks by 30dB to line level.

4. HIGH FREQUENCY(HF) – control knob

The HF knob controls the amount of treble applied to that channel. The channel's HIGH frequency response is flat when the knob is in the "12:00" position. Rotating the knob towards the right will boost the channel's high frequency response above 10 kHz by 15dB, and rotating it towards the left will cut the high frequency by 15dB.

5. LOW FREQUENCY (LF) – control knob

The LF knob controls the amount of bass applied

to that channel. The channel's LOW frequency response is flat when the knob is in the "12:00" position. Rotating the knob towards the right will boost the channel's low frequency response below 100 Hertz by 15dB, and rotating it towards the left will cut the frequency by 15dB.

6. REVERB – switch (channels 1 - 4)

Use the REVERB switch to add a reverb effect to a mic or line input on any of the inputs 1 – 4. The REVERB switch is used in conjunction with the master REVERB return control knob #23.

7. REVERB LED – indicator (channels 1 - 4)

The REVERB LED will illuminate when the REVERB switch is pressed down indicating the channel is set to add reverb. See number 6 above.

8. VOLUME (VOL) – control knob

Sets the overall level for the Mic or Line input.

9. Stereo Inputs (channels 5 / 6)

The XP308i has a pair of 1/4-inch jacks for connecting stereo line level sources. For stereo inputs, use the LINE L to connect the left channel and the LINE R to connect the right channel. Use these inputs to connect high impedance microphones, synthesizers, drum machines, MP3, CD, tape players or any other line level device.

XP308i Mixer Layout

10. Stereo Inputs RCA (channels 5 / 6 and 7 / 8)

The XP308i mixer features stereo line level inputs using RCA connectors on channels 5/6 and 7/8. Use these RCA inputs for connecting the output of devices such as MP3, CD, computer soundcard, cassette player, or any other line level device.

11. MONITOR OUT - 1/4-inch phone jacks

The signal present at the MONITOR OUT jacks is sent from the MONITOR level control knob, which is fed from the input channels. In many live sound situations, a monitor speaker is set up facing the performer or speaker. The XP308i provides a dedicated output, with level control (see 21) to send the stereo mix to a monitor speaker or speakers. To run a monitor from it XP308i, use the MONITOR OUT by connecting the to a powered monitor or power amp and monitor speaker.

12. REC OUT - RCA jacks

This output is used to send the main mix to an external recorder. The signal present at this connector is the MAIN bus signal before it has passed through the MASTER level control. The nominal output level is -10dBV and the impedance is 100 Ohms.

13. SPEAKER OUT - 1/4-inch phone jacks

The XP308i has two 1/4-inch phone connectors, which are powered outputs used to connect your left and right speaker. Use the included speaker cables to connect the speakers.

CAUTION: The total impedance load for each side of the amplifier must not exceed 4 Ohms, therefore do not connect additional speakers to the XP308i mixer.

14. AC - IEC inlet

Connect the supplied heavy-gauge 3-pin "IEC" power cable here.

15. POWER - switch

Use this to turn power to the XP30i on or off.

16. iPod DOCK - connector

The XP308i has a built in iPod dock which can be used to connect most of the latest iPod models.

17. Phantom LED indicator

The LED will illuminate whenever the Phantom Power switch is pressed.

18. PHANTOM - switch

The XP308i features an onboard, 48-Volt Phantom power supply to operate condenser microphones. When the switch is engaged, the LED will illuminate indicating that phantom power is now available on the microphone pre-amps.

IMPORTANT NOTE: To avoid a loud pop, be sure to turn down the MASTER level controls before plugging and unplugging the mic cables when the phantom power is active.

19. POWER LED - indicator

The Power LED will illuminate when the MAIN power switch is turned on.

20. SPEECH /MUSIC - switch

The SPEECH MUSIC switch is use to change the overall frequency response, or tone contour for the XP308i sound system. The SPEECH setting boosts the mid a little for vocal articulation, while the MUSIC setting boost the lows and highs for a more hi-fi sound. If your application is mainly for MUSIC, press the switch down to select the MUSIC response curve. If your application is mainly for speech, leave the switch up to select the speech response curve.

21. MONITOR - control knob

The MONITOR volume control is used to control the overall level sent to the MONITOR OUT, which can be used to send to a second set of powered speakers for monitors.

22. MASTER - control knob

The Master volume knob controls the overall output level. This knob determines the final output signal level. Signals from all eight channels are routed here just before being routed to the built-in power amplifiers and Left and Right output jacks (see #13 above).

23. REVERB - control knob

The REVERB control knob is use to adjust the total amount of reverb added to any channels with their REVERB switch (see #6 above) pressed down.

24. METER - LED indicators

This six-segment bar meter shows the XP308i's output level. For optimum signal-to-noise ratio, set the Volume control so that program material is usually at or around +3 to +6 VU, with occasional but not steady excursions to the red "LIMIT" segment.

Operating the XP308i

Setting up The XP308i system

1. Remove the accessory compartment cover by turning the quarter turn screw counter clockwise towards the RELEASE position and remove the included speaker cables.

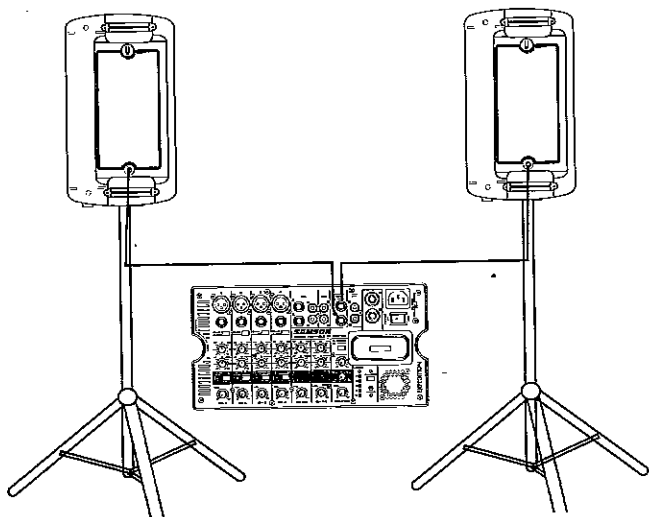

2. Remove the mixer by turning the quarter turn screw counter clockwise towards the RELEASE position.

IMPORTANT NOTE! – In order to ensure proper ventilation, always remove the mixer before powering it on.

3. Place the mixer on a table-top and extend the kickstand to provide a comfortable, ergonomically correct mixing angle. For added flexibility, you can attach a standard mic stand adapter to the bottom of the mixer for mounting on a standard microphone stand.
4. Plug the power cable into an available power source but keep the mixer's POWER switch off for now.

Note: The XP308i's power supply is a universal voltage, switching supply, so it will operate on any voltage from 100 to 240 volts.

5. Position the speakers on the floor or on stands. In order to minimize the possibility of feedback, be sure to carefully consider where you locate the speakers. It's always a good idea to place the speakers in front of any live microphones. If possible, use speakers stands to help project the sound above the audience. Since the XP308i's speakers include built-in standard, 1 3/8-inch (35mm) speaker stand receptacles, you can use

most any speaker stands without the need for any additional adapters. *The LS2, TS50 and TS100 speaker stands from Samson are recommended.*

- Using one of the included speaker cables connect the mixer's LEFT SPEAKER OUT to the left speaker's input connector.
- Next use the second included speaker cable to connect the RIGHT SPEAKER OUT to the right speaker's input connector.

Connecting Microphones And Instruments

1. Before connecting your microphones or instruments, make sure that the power of all your systems components, including the XP308i, is turned off. Also, make sure that the VOLUME controls of each channel of the XP308i and the MASTER level control are turned all the way down.
2. Connect the cables to your microphones and instruments, and insert the other end of the cable firmly into the appropriate input on the XP308i.

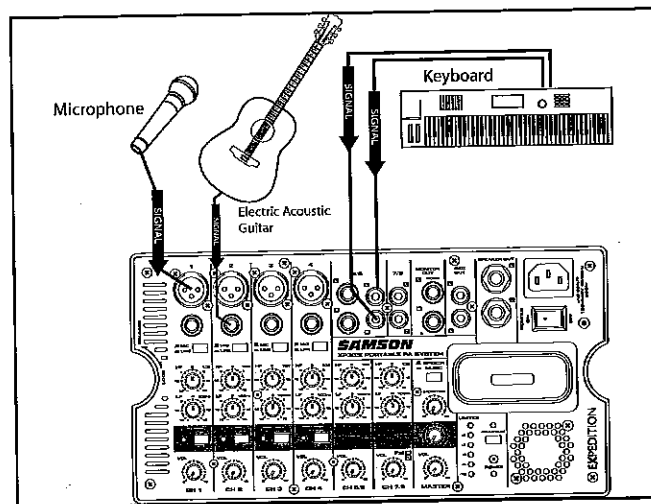

3. Switch on the power of any peripheral devices, and then power up the XP308i.

NOTE: Since the XP308i contains two power amplifiers, it is important to remember the Golden Rule of audio ... "LAST ON, FIRST OFF". Translated, this means that when turning on your system, you should always turn your power amplifiers on LAST, and when turning your system off, turn your power amps off FIRST. This helps avoid any loud pops caused by inrush current at power up or power down, which can sometimes damage loudspeakers.

Operating the XP308i

4. Set the MASTER level control to about halfway up.
5. While speaking into the mic (or playing the instrument), adjust the channel GAIN control so that the "PEAK" LED of the channel lights occasionally, then back it down slightly.

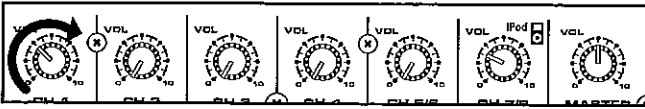

6. Slowly adjust the channel VOLUME control until the desired level is reached.
7. If you wish to adjust the tone of each channel, adjust the LF and HF equalizer controls as desired. If you add a lot of EQ, you may have to re-adjust the channel VOLUME.
8. Use the MASTER level control and SPEECH / MUSIC switch to adjust the overall volume and tone.

Using The Reverb Effect

The XP308i features a built-in, high quality, Reverb effect that you can add to channels 1 through 4. You can use the REVERB to create a studio effect by simply following the steps below.

1. Connect a mic or instrument to the desired channel, and adjust the volume and equalizer to your liking.
2. Now press the REVERB switch down on the channel you want to add the reverb effect to.
4. Once you have selected the channels for effects by using the channel REVERB switch, raise the



REVERB main level control to apply the amount of reverb effect.

NOTE: If the effect sound is distorted, lower the REVERB main level.

Using Monitor Speakers.

In many live sounds applications, it's necessary to have a monitor system to help the performers hear their performance. A monitor system includes a dedicated signal from the main mixer feeding amps and monitor speakers, or powered monitor speakers, facing the performers on stage.

Monitor speakers are typically angled enclosures and can be miniature stand mounted monitors used in small situations, or for medium to large PA set-ups floor monitors are used.

The XP308i's mixer provides a MONITOR OUT on two 1/4-inch phone jacks for connecting additional speakers.

Follow these steps to connect your monitor speakers.

Be sure to select the correct type of monitor speakers. The MONITOR OUT is a line level, un-powered output so you must use a powered monitor (like the Samson LIVE 612M) or a passive monitor with a power amp.

Place the monitor in position.

Connect a standard, shielded instrument type cable with 1/4-inch phone plugs from the MONITOR OUT Left and Right jacks to the input of each monitor as shown in the diagram below.

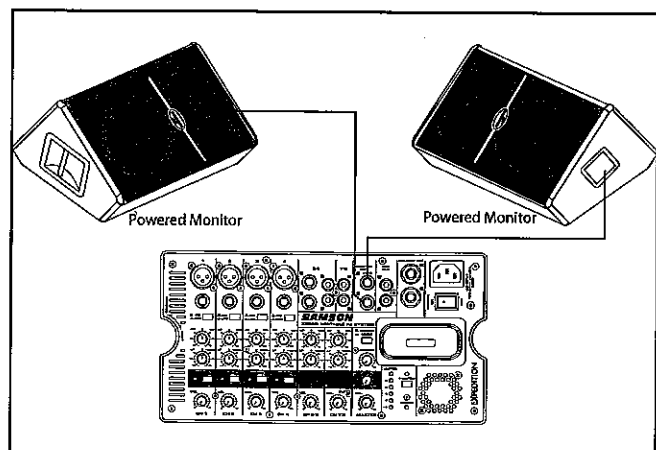

Operating the XP308i

Using The iPod Docking Station

The XP308i has a built-in iPod docking station fit neatly into the top of the XP308i's mixer allowing you to interface the latest iPod MP3 players to provide background music for meetings or performances. Follow the steps below to install your MP3 player.

1. Before you connect your iPod, check to see if it came with a dock adapter. If your iPod player came with a dock adapter, fit it in the XP308i's docking station.
2. Next, simply place the iPod player in the dock.

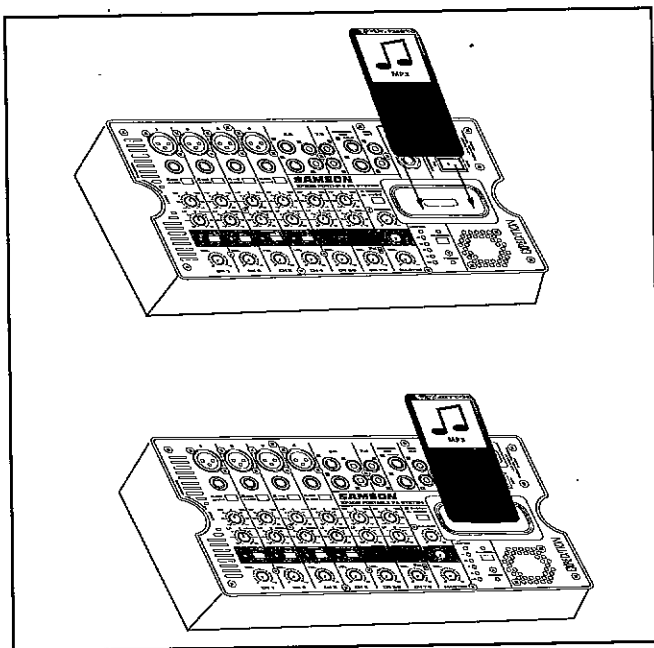

3. If an optional iPod MP3 player is installed, its output arrives at 7/8, so use the channel 7/8 VOLUME control to adjust the iPod's playback volume.

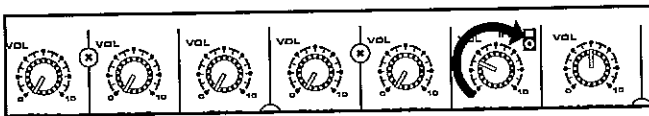

Recording Your Performance From The XP308i

You can record the audio from the XP308i's mixer section including the MIC, LINE, TAPE IN and AUX inputs to a cassette deck, MD, DAT, iPod or any other type of recorder using the record outputs. Simply connect the XP308i's REC OUT jacks to the input jacks of the recorder as shown in the diagram below.

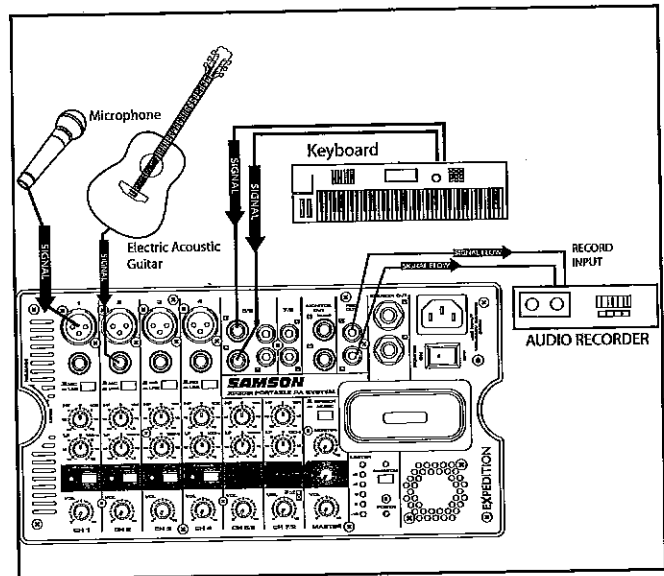

Operating the XP308i

Configuring the XP308i for Carry Case

You can easily carry your sound system using the XP308i's "Slide and Lock" feature. The "Slide and Lock" speaker enclosures allow you to connect both speakers together into a single easy to carry unit. Follow these simple steps to configure the XP308i for easy transport.

- Place one speaker on the floor and set it on its side.

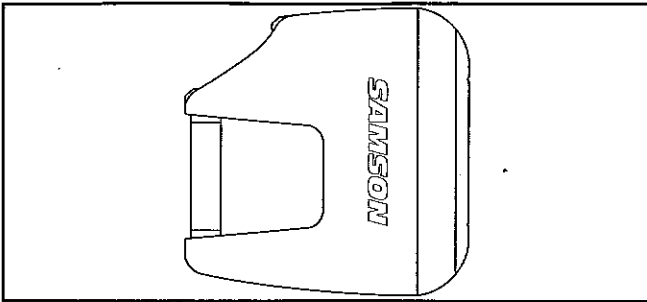

- Grab the second speaker and while holding it above the first speaker, line up the "slide and lock" tracks and grooves so they are parallel with the speaker on the floor.

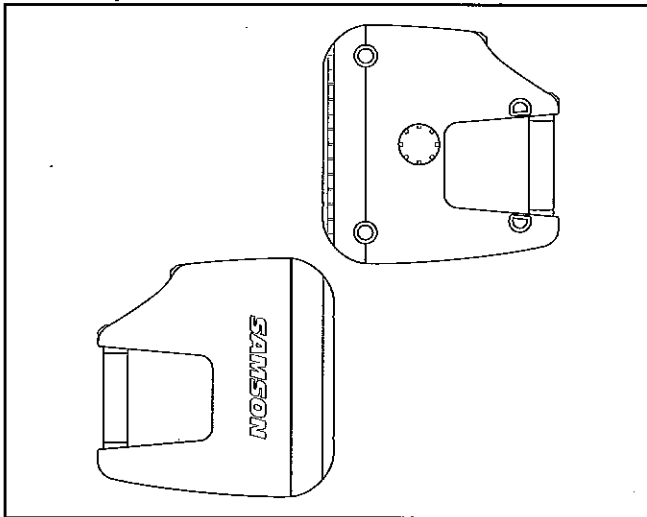

Configuring the XP308i for Carry Case

- Slide the second speaker into the speaker on the floor making certain that the two speakers stay parallel to each other.

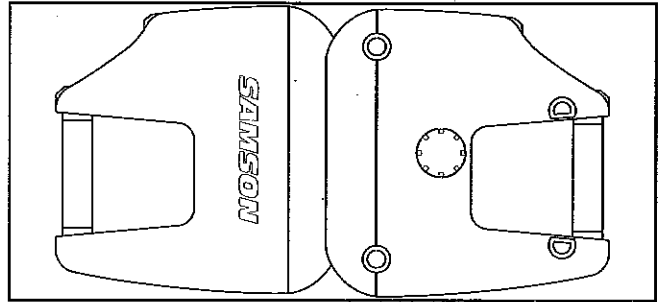

- You will feel a slight click when the two speakers are in place.

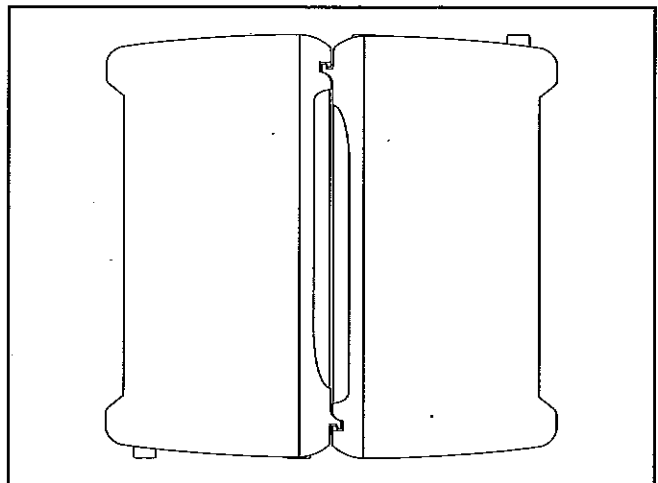

XP308i System Set-ups

Live Band PA System With Monitors

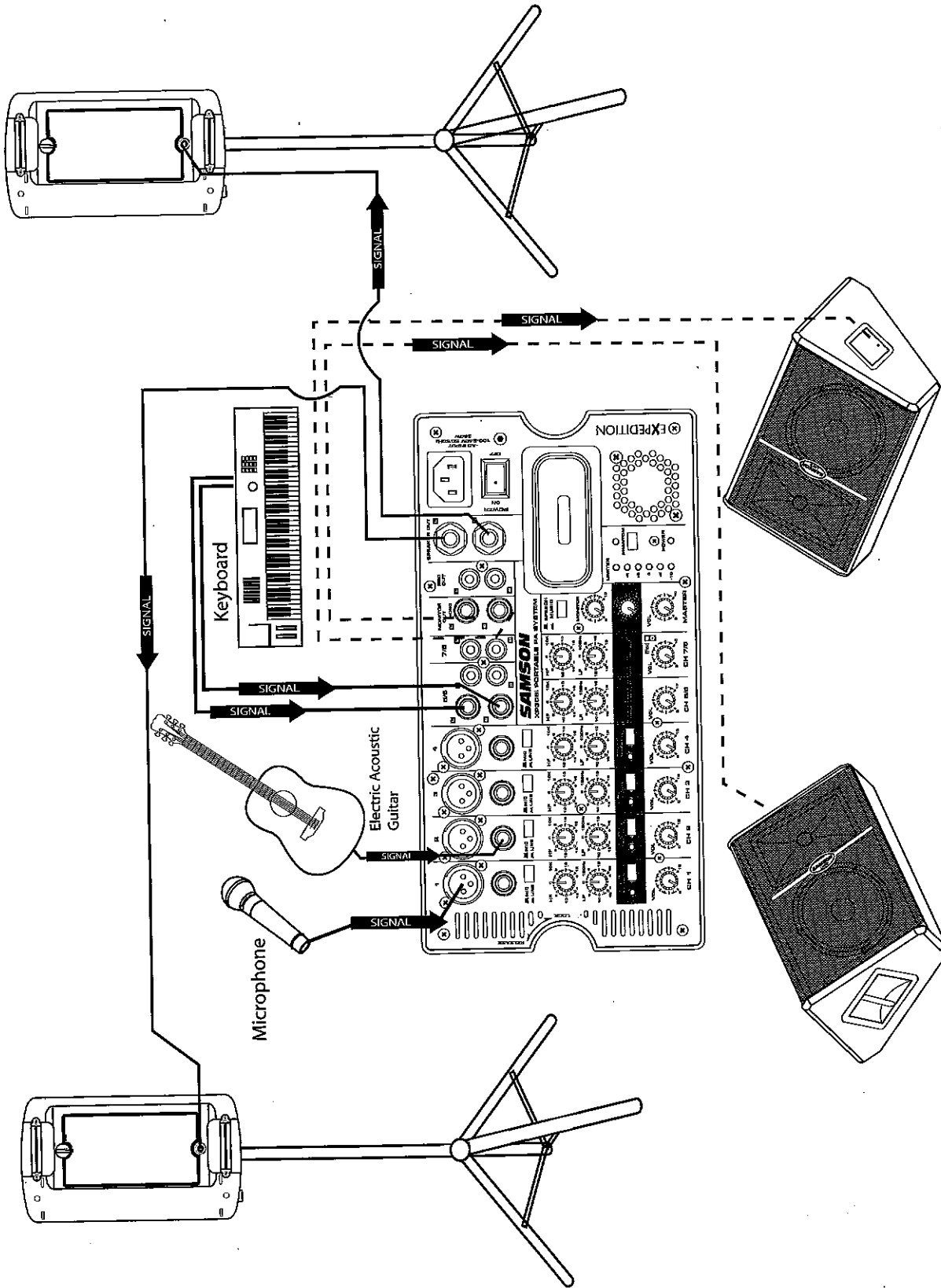

This example shows a typical PA system for a band using the XP308i with microphones, acoustic guitar and keyboards connected. A separate signal from the XP308i mixer's MONITOR OUT is sent to two Samson LIVE 612M powered floor monitors.

XP308i Wiring Guide

CONNECTING THE XP308i

There are several ways to interface the XP308i to support a variety of applications. The XP308i feature balanced inputs and outputs, so connecting balanced and unbalanced signals is possible.

Unbalanced 1/4" Connector

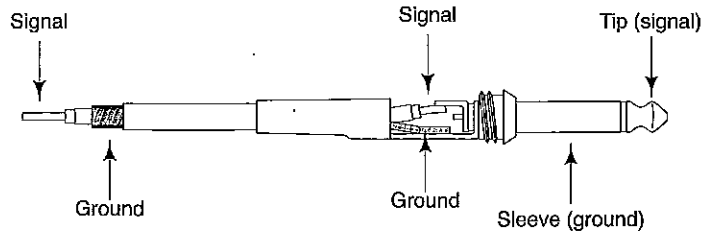

Balanced TRS 1/4" Connector

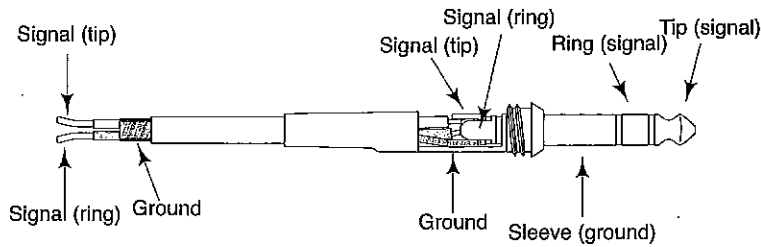

XLR Balanced Wiring Guide

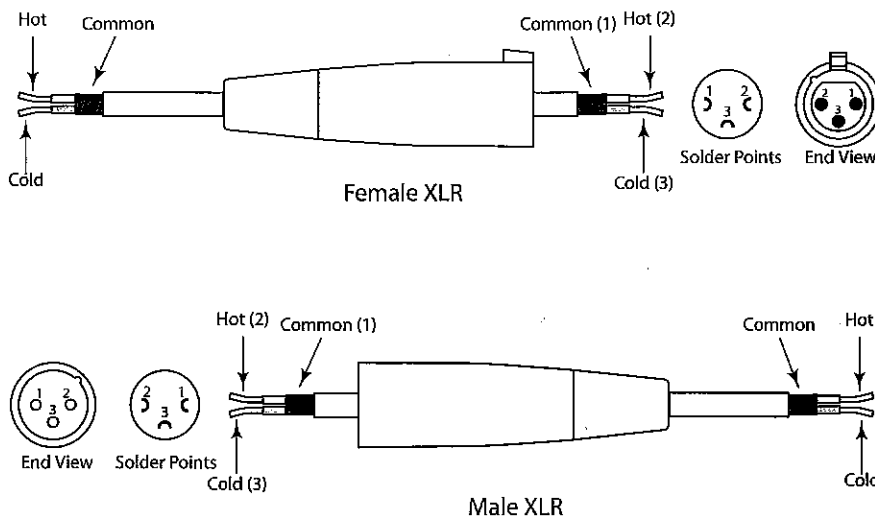

Specifications

Input Specifications

Input Connector	Input Impedance	Nominal Load Impedance	Rated Input Level	Connector Type
CH Mic	3.6K Ω / 7.5K Ω	50~600 Ω / 600 Ω	-36dBu / -26dBu	XLR Type Balanced / Phone Jack(TRS)T=Hot R=Cold S=GND
CH Line	3.6K Ω / 7.5K Ω	50~600 Ω / 600 Ω	-6dBu / +4dBu	XLR Type Balanced / Phone Jack(TRS)T=Hot R=Cold S=GND
Stereo Input	10K Ω	600 Ω	-10dBu	Unbalanced Phone Jack
Stereo Input	10K Ω	600 Ω	-10dBu	RCA pin Jack

Output Specifications

Output Connector	Output Impedance	Nominal Load Impedance	Rated Output Level	Connector type
MONITOR L/R	1K Ω	600 Ω	+4dBu	Phone Jack (TRS) Impedance balanced [T:hot; R:Cold; S:ground]
Rec Out	600 Ω	10K Ω	-10dBu	RCA pin Jack
Speaker Output	100 Ω	8 Ω	110W	Phone Jack

System Specifications

Maximum Output Level (0.5% T.H.D at 1KHz)	+22dBu(MONITOR L/R) @10K Ω +14dBu(REC) @10K Ω More than 110W(SPEAKER) @8 Ω	
T.H.D	<0.1% @+14dB 20Hz~20KHz (MONITOR L/R,REC L/R) @10K Ω <1% @ 110W 20Hz~20KHz (SPEAKER OUTPUT) @8 Ω	
Frequency Response	20Hz~20KHz,(MONITOR L/R,REC L/R,SPEAKER OUTPUT) @10K Ω	
Hum and Noise Input GAIN=Maximum Input sensitivity -50dBu	-112dBu	equivalent input noise (Rs=150 Ω)
	-90dBu	Residual noise (MONITOR L/R) all Level at Minimum
	-80dBu	MONITOR VR at nominal level and all channel Level Minimum.
	-70dBu	MONITOR VR at Maximum level and all channel Level Minimum.
Maximum Voltage Gain	64dB MIC(XLR) IN TO MONITOR L/R 54dB MIC(PHONE TRS) IN TO MONITOR L/R 34dB LINE(XLR) IN TO MONITOR L/R 24dB LINE(PHONE TRS) IN TO MONITOR L/R 28dB ST LINE IN TO MONITOR L/R 38dB MIC(XLR) IN TO REC L/R	
Crosstalk (at 1KHz)	-70dB between input channels	
	-70dB between input/output channels (CH INPUT).	
SPEECH/MUSIC	75Hz, 18dB/Octave	
Input Channel Equalization	HIGH:10KHz shelving \pm 15dB	
	LOW:100Hz shelving \pm 15dB	
REVERB indicators	within.	
LED Meters	5-point LED,SPEAKER OUT	
LIMITER Indicators	LIMITER:An indicator for master turns on when the speaker output below clipping.	
Phantom Power	+15V DC	
Power Source/Power Consumption	AC INPUT 100V~240V,50/60Hz 360W	
Weight	37.43lb.(16.8Kg)	
Dimensions	20.1"(W)*10.6"(D)*19.1"(H) , 510mm(W)*270mm(D)*485mm(H)	

Where 0dBu=0.775V and 0dBV=1V

Specifications are subject to change without notice.

Block Diagram

XP308i BLOCK DIAGRAM

